

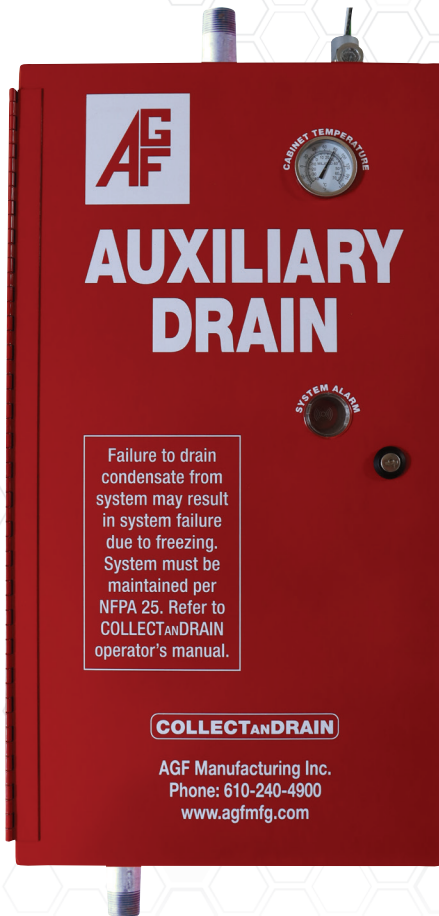

**COLLECT<sub>AN</sub>DRAIN<sup>®</sup>**

**Model 5500**



Failure to drain condensate from system may result in system failure due to freezing. System must be maintained per NFPA 25. Refer to COLLECT<sub>AN</sub>DRAIN operator's manual.

**COLLECT<sub>AN</sub>DRAIN**

AGF Manufacturing Inc.  
Phone: 610-240-4900  
www.agfmfg.com

**Owner's Manual**

**www.agfmfg.com**

# COLLECT<sub>AND</sub>DRAIN<sup>®</sup>

## Model 5500

### Automatic Auxiliary Drain with Freeze Protection

#### TABLE OF CONTENTS

<b>Quick Reference Guide</b> .....	<b>3</b>
<b>Installation Instructions</b> .....	<b>4-6</b>
Unpacking.....	4
Sprinkler System Preparation.....	4
Mounting.....	4
Wiring.....	5
Verify Correct Operation.....	6
<b>Operating Instructions</b> .....	<b>7-10</b>
Drain Cycle.....	8-9
Drain Override.....	10
<b>Maintenance Instructions</b> .....	<b>10-11</b>
Conduct a Drain Cycle.....	10
Verify Alarm Operation.....	10
Verify Heater Operation.....	10-11
Change Thermostat Setting.....	11

#### Model 5500 COLLECT<sub>AND</sub>DRAIN<sup>®</sup>

The COLLECT<sub>AND</sub>DRAIN<sup>®</sup> Model 5500 is a heated and insulated auxiliary drain (condensate collector/drum drip) with a programmable logic control (PLC), which enables fully automatic or on demand push-button operation. The Model 5500 is designed for installation in climates where freezing or below freezing temperatures are present and result in the failure of typical collectors. The Model 5500 maintains a comfortable temperature above freezing while minimizing power consumption.

**CAUTION:** The heater and its deflector bracket may be hot. Use care when accessing the main cabinet for any reason.

#### **AGF Manufacturing**

100 Quaker Lane • Malvern, PA 19355

Phone: 610-240-4900  
techsupport@agfmfg.com

[www.agfmfg.com](http://www.agfmfg.com)

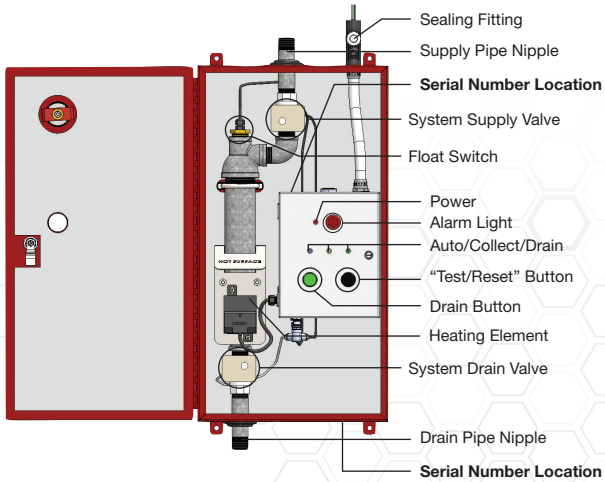

## Quick Reference Guide

LAMPS	INDICATES
Power	Unit is on.
Auto	The automatic mode is on. Unit will automatically drain when full of condensate.
Collect	Unit is collecting condensate. The supply valve is open and the drain valve is closed.
Drain	Unit is draining condensate. The supply valve is closed and the drain valve is open.

OPERATION	PRESS
Drain Condensate	Drain button for one (1) second or press remote drain button.
Test Electronics	Test/Reset button for one (1) second to verify lamps, main alarm, and dry auxiliary contacts are functioning.
Auto On/Off	Test/Reset button four (4) times quickly to turn on and off the automatic drain mode.
Reset Lamp Flash	Test/Reset button for one (1) second.
Reset System	Test/Reset button for five (5) seconds will reboot the system and return to collect state.
Drain Override	Drain and Test/Reset buttons simultaneously for three (3) seconds. WARNING: Use this ONLY when servicing the sprinkler systems and system has been taken offline. Otherwise, this will fully open the auxiliary drain causing the sprinkler system to activate.

ALARMS	INDICATES
Main Alarm/Dry Contacts, ONLY	<b>If Auto Drain Mode is not activated:</b> Condensate is full. <b>If Auto Drain Mode is active:</b> System is actively draining.
Collect Lamp, Single Flash	Malfunction with supply valve. Valve did not fully open or close during last cycle.
Drain Lamp, Single Flash	Malfunction with drain valve. Valve did not fully open or close during last cycle.
Drain Lamp, Double Flash	Malfunction, the level switch failed to reset during last drain cycle. The collection pipe is still full of condensate.
Power Lamp, Single Flash	Malfunction, heater has been continuously operating for at least two (2) hours.
Power Lamp, Double Flash	An auto drain cycle has been performed.
Dry Contact, ONLY	No electrical power to unit

## INSTALLATION INSTRUCTIONS

### Unpacking:

1. Unpack the COLLECT<sub>AN</sub>DRAIN<sup>®</sup> M5500 unit and carefully inspect for any shipping damage.
2. Verify box contents:
  - COLLECT<sub>AN</sub>DRAIN<sup>®</sup> M5500 unit
  - Four (4) Rubber Mounting Washers
  - Two (2) Door Keys
  - Electrical Wiring Schematic
  - M5500 System Drawing

### Sprinkler System Preparation:

If installing to an existing system, follow instructions below prior to proceeding to Mounting Instructions:

1. Isolate the zone where the COLLECT<sub>AN</sub>DRAIN<sup>®</sup> will be installed.
2. Relieve air pressure from the branch line.
3. Remove the existing auxiliary drain.

### Mounting Instructions:

**NOTE:** For installation locations exposed to weather, the Model 5680A Outdoor Cover is **REQUIRED**. For exposed installations on columns, uneven or curved surfaces, or where cabinets need to stand off the wall to accommodate surface mounted drain pipe, the Model 5690A Mounting Kit may also be required.

Use the four mounting tabs (3/8" holes x 4) to install the M5500 to a wall or other secure structure. If wall is uneven use bushings or standoffs to prevent cabinet from bending when mounted.

1. Place the rubber washers behind the mounting tabs to hold the M5500 off of the wall. Select fasteners suitable for attachment and capable of supporting the 58 lb. weight of the M5500.
2. Connect dry system to 1" NPT supply pipe nipple in accordance with NFPA 13 requirements regarding low-point drain installations.
3. Connect the 1" NPT drain pipe to suitable drain plumbing capable of accepting the discharge and directing it to a drain connection or other safe location in order to avoid a potential slip and fall situation. The use of an air gap is recommended.

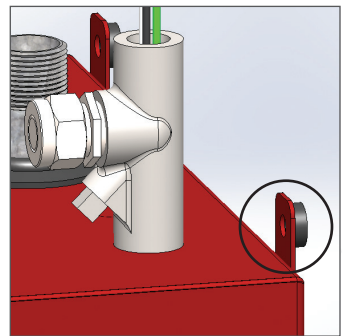

## Wiring:

The M5500 is wired with 12 AWG power leads and is protected by an internal 3A circuit breaker that requires a 120VAC power source. Ensure the breaker in the main electrical panel is sized appropriately.

**WARNING: The M5500 comes with power leads wired through a sealed drain fitting per NEC 300.7 (A) “Raceways Exposed to Different Temperatures”. If wiring is added or changed into the control panel, NEC 300.7 (A) requires the electrical conduit be filled with an approved material after the wiring is complete. An approved sealant, sealing fitting, or low-point junction box must be installed at the cabinet coupling. Failure to do so risks condensation intrusion into the control panel resulting in potential system failure and will void all warranties.**

1. Install a low-point junction box within reach of the provided power leads.
2. Run conduit to the ½” fitting on top of the unit, pull power leads through conduit and connect leads to wiring from main electrical panel.
3. To turn on the M5500, open the control panel using a slotted screwdriver. Then, push the internal circuit breaker up; breaker indicator will change from green to red. After the PLC starts, the power and other door lights will illuminate.
4. Confirm operation by pushing test button on door. Alarm will sound/flash, dry contacts will close and all door lights will illuminate.

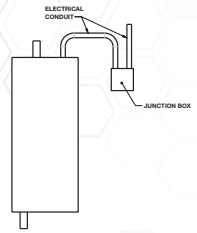

The M5500 can be connected to a remote panel to indicate when it needs to be drained, provide the ability to drain it remotely, and indicate when it has lost electrical power. This is accomplished through two pairs of terminals. One pair is N.O. (close on alarm or power loss) dry auxiliary contacts. The second pair is for connecting a remote operation drain button.

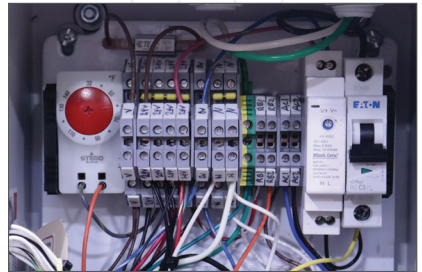

**NOTE:** If required, an additional port and knockout are provided in the panel and cabinet for low-voltage wire. **Ensure installer-provided items are liquid tight and the conduit is internally sealed per NEC 300.7 (A).**

1. Run additional wires into the M5500 electrical enclosure.
2. Connect one pair of wires to the top of the AC1 and AC2 terminals to remotely monitor the alarm and power status.
3. Connect an additional pair of wires to the top of the RB1 and RB2 terminals to remotely drain the system.
4. Connect all wires to the appropriate places in the Remote Panel.

**Verify Correct Operation:**

1. Apply power to the M5500 and verify that correct voltage is present.
2. Turn on the circuit breaker inside of the M5500 electrical enclosure.
3. Confirm the supply valve is open; the red line on its cover will be vertical.
4. Confirm the drain valve is closed; the red line on its cover will be horizontal.
5. Press the Test/Reset button on the front cover and hold for one to two seconds to verify that the alarm horn sounds, and all the cover lamps work.
6. Press the drain button on the cover and hold for one second. The system will perform an on demand drain cycle which takes approximately one minute to complete. Refer to the Drain Cycle section later in this manual for more information.
7. Turn the red thermostat set-point dial clockwise until the heater turns on.
8. Reset the red thermostat set-point dial to the factory default setting of 70° F.



Supply Valve



Drain Valve

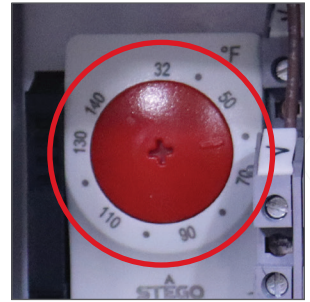

**NOTE:** It is the owner's responsibility to set the thermostat based upon the climate conditions of the installed location. The default setting of 70° F is adequate for outside temperatures down to 0° F and to offset the minor heat generated by the PLC. If operating below this temperature, the set-point should be increased. Consult AGF for set-point guidelines.

9. Close the M5500 electrical enclosure cover and secure latch with a slotted screwdriver.
10. Ensure the system's drain activation is setup as desired. If the Auto lamp is on, the system will automatically drain when the level switch indicates the collection pipe is full. If the Auto lamp is off, the system will alarm when full, but not drain itself. To switch between the two settings, press the Test/Reset button four (4) times quickly.
11. Close and lock the door using the supplied keys.

**NOTE:** If installation was to an existing system, return the system back to normal operating conditions. If installation was to a new system, activate system for normal operating conditions.

## OPERATING INSTRUCTIONS

The M5500 is equipped with a Programmable Logic Control (PLC) which monitors the status of the unit, controls the drain cycle, and provides feedback based on input it receives from the level switch, thermostat, and motorized ball valves. The PLC offers the ability to conduct automatic draining of the condensate when it is full or on demand draining at any time.

The system uses a float-style level switch to monitor the amount of condensate collected. When enough condensate has accumulated, the level switch is activated. This informs the PLC which triggers the alarm to sound and blink the red light mounted on the M5500 electrical enclosure. If the M5500 is in automatic drain mode (indicated by the auto lamp being on) the system will automatically step through a drain cycle. If the M5500 is not in automatic drain mode (on demand mode), the alarm will activate as before, but the drain cycle will not start until the local drain button is pressed or, if it has been wired, the remote button is pressed. While the alarm is active, an auxiliary contact is also triggered and is capable of being wired back to a central control panel for remote indication. The alarm and auxiliary contacts are automatically reset when the drain cycle is successfully completed, and the condensate level is drained below the switch.

When the M5500 is in automatic drain mode it will initiate a drain cycle every 30 days, regardless of the water level in the collection assembly. This is done to exercise the valves regularly, and maintain operational integrity. **When the M5500 is in manual drain mode it is the responsibility of the user to exercise the valves on a regular basis by prompting a drain cycle.**

Based on the setting of the thermostat, the PLC will activate a 150W heater. The factory default setting of 70° F is suitable for conditions down to 0° F. Consult with AGF for recommended settings if operating the M5500 in an area below 0° F. The thermostat controls the heater operation to within approximately  $\pm 10^{\circ}$  F of the set-point (i.e. S.P. 70° F, on @ 60° F, off @ 80° F).

**NOTE:** AGF does not recommend setting the thermostat below 70° F.

In addition, if the thermostat calls for the heater to be continuously on for two hours, the PLC will activate the alarm and auxiliary contact as before, and single flash the power lamp. This is to notify the operator that there is an issue with maintaining the desired temperature which could be a result of the cabinet door being left open or the heater not keeping up with temperature demand.

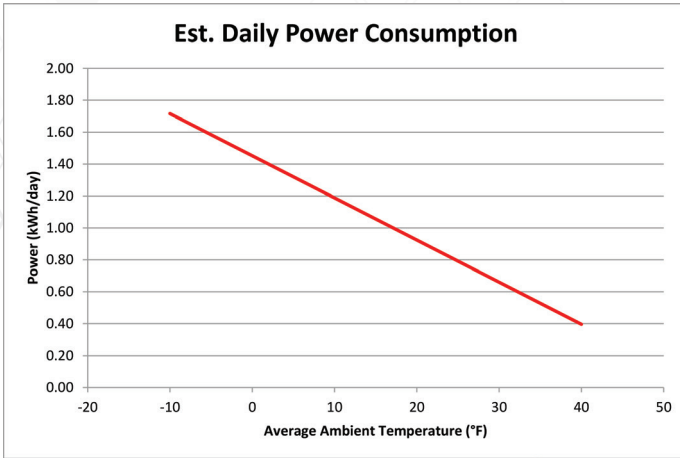

Power consumption of the M5500 is based on several factors including ambient temperature, humidity, installation location and exposure to sunlight. The following graph shows an estimation of the daily energy consumption verses the ambient temperature when the set-point is 70° F.

The M5500 features a thermometer on the cabinet door for measuring the ambient temperature inside the unit. This thermometer is for checking the operating status of the heater. The reading on the thermometer, based on its location in the cabinet, may range from 40° to 120° F depending on when in the heater’s cycle it is viewed.

The M5500 is equipped with a “Test/Reset” button to confirm that the electrical enclosure is functioning properly. When pressed, it causes all the lamps to turn on and the local alarm horn/light, as well as, the auxiliary contact to be triggered.

**Drain Cycle:**

The drain cycle may be initiated automatically or on demand at any time. If the auto lamp is “on” the system is in automatic drain mode, if the auto lamp is “off” the system is in on-demand mode and will NOT drain until the local drain button is pressed, or if wired by the installer, the remote drain button is pressed. The local drain button must be pressed for at least one (1) second to initiate the on-demand drain cycle. To change between the two modes press the Test/Reset button rapidly four (4) times, the auto light will illuminate if successful. As previously mentioned, a drain cycle will be performed once every 30 days if the M5500 is in automatic mode.

Whether it is initiated automatically or on demand, the steps the PLC performs during a drain cycle are as follows:

1. Turns off the collect lamp and close the supply valve. The red line on the valve's actuator will rotate from vertical to horizontal. The PLC confirms the upper valve is closed before proceeding.
2. Opens the drain valve. The red line on the valve's actuator will rotate from horizontal to vertical. The PLC confirms the drain valve is open before proceeding.
3. Turns on the drain lamp.
4. Allows the system to drain for approximately 40 seconds.
5. Turns off the drain lamp.
6. Closes the drain valve; PLC confirms this valve is closed before proceeding.
7. Opens the supply valve; PLC confirms this valve is open before proceeding.
8. Turns on the collect lamp.

If at any time during the drain cycle the PLC senses a malfunction such as the valves not fully actuating or the condensate not draining from the system, the system alarm will stay on, or enter the alarm state. Refer to the Quick Reference section to determine the cause of the alarm if it is the result of a malfunction. Once the issue is corrected, press the Test/Reset button for one (1) second to clear the malfunction.

#### NOTES:

If the cycle is automatically initiated, the alarm and auxiliary contact will be active until the drain cycle successfully completes. If the cycle is initiated on demand, the alarm and auxiliary contact will shut off as soon as the level switch resets. The drain cycle takes about one minute to complete.

**WARNING:** The heater and it's deflector bracket may be HOT. Use care when entering the main cabinet for any reason.

When servicing the unit, the actuation of the valves may be performed manually. First, ensure power to the system is turned off. Then, pull up on the blue knob located on the actuator cover until it clicks and turn the knob until the desired valve position is reached.





### Drain Override:

**WARNING:** The following feature is for use **ONLY** when servicing the sprinkler system and system has been taken offline. The Drain Override will fully open the auxiliary drain causing the sprinkler system to activate if it has not already been depressurized.

If the M5500 must be completely opened, press the Drain and Test/Reset buttons simultaneously for three (3) seconds. This will open the drain valve without closing the supply valve. After waiting for at least 40 seconds, press both buttons again to go back to the collect state.

## MAINTENANCE INSTRUCTIONS

Maintenance is the cornerstone to keeping any system operating correctly and efficiently. It is the building owner's responsibility to ensure that the M5500 has been drained of condensation and that the heater and alarm are working properly. Failure to drain condensation from the system, or conduct regularly scheduled testing and maintenance could result in system failure due to freezing. System must be maintained per NFPA 25.

It is *especially important* that functional testing of the drain cycle and heater be performed before the start of the winter season or when temperatures begin to approach freezing conditions.

### Conduct a Drain Cycle:

On the electrical enclosure, press the "Drain" button for one second to start the cycle. Verify that the unit drains any residual condensate and the cycle completes successfully.

### Verify Alarm Operation:

On the electrical enclosure, press the "Test/Reset" button for one to two seconds to verify that all lamps turn on, the alarm horn sounds, and the alarm light blinks.

### Verify Heater Operation:

**CAUTION:** Always take the necessary precautions when entering the electrical enclosure when 120V power is present.

1. Using a slotted screwdriver, unlock and open the door of the M5500 electrical enclosure.
2. Take note of the current thermostat set-point.

**Thermostat Set-Point:** \_\_\_\_\_

3. Turn the red Thermostat Set-Point dial clockwise until the heater turns on.
4. Reset the red Thermostat Set-Point dial to the previous setting.
5. Close the M5500 electrical enclosure door and lock the latch with a slotted screwdriver.

**Change Thermostat Setting:**

**NOTE:** It is the owner's responsibility to set the thermostat based upon the climate conditions of the installed location. The default setting of 70° F is adequate for outside temperatures down to 0° F. If operating below this temperature, the set-point should be increased. Consult AGF for set-point guidelines.

1. Disconnect electrical power to the M5500.
2. Using a slotted screwdriver, unlock and open the door of the M5500 electrical enclosure.
3. Turn the red Thermostat Set-Point Dial clockwise or counterclockwise to the desired setting.
4. Take note of the new thermostat set-point.

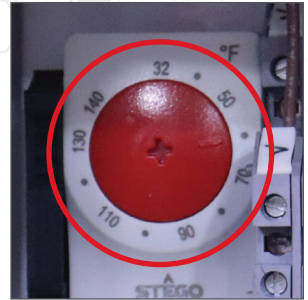

**Thermostat Set-Point:** \_\_\_\_\_

5. Close the M5500 electrical enclosure door and lock the latch with a slotted screwdriver.
6. Apply power to the M5500.

**MAINTENANCE LOG**

<u>Initials</u>	<u>Maintenance Description</u>	<u>Date</u>
_____	_____	_____
_____	_____	_____
_____	_____	_____
_____	_____	_____
_____	_____	_____
_____	_____	_____
_____	_____	_____
_____	_____	_____
_____	_____	_____



**AGF Manufacturing**  
100 Quaker Lane • Malvern, PA 19355

Phone: 610-240-4900  
techsupport@agfmfg.com

**[www.agfmfg.com](http://www.agfmfg.com)**